

**SCHMEISER®**

# **3-PT. CULTI-PLOW**

**2-bar and 3-bar models**

## **ASSEMBLY & PARTS MANUAL**

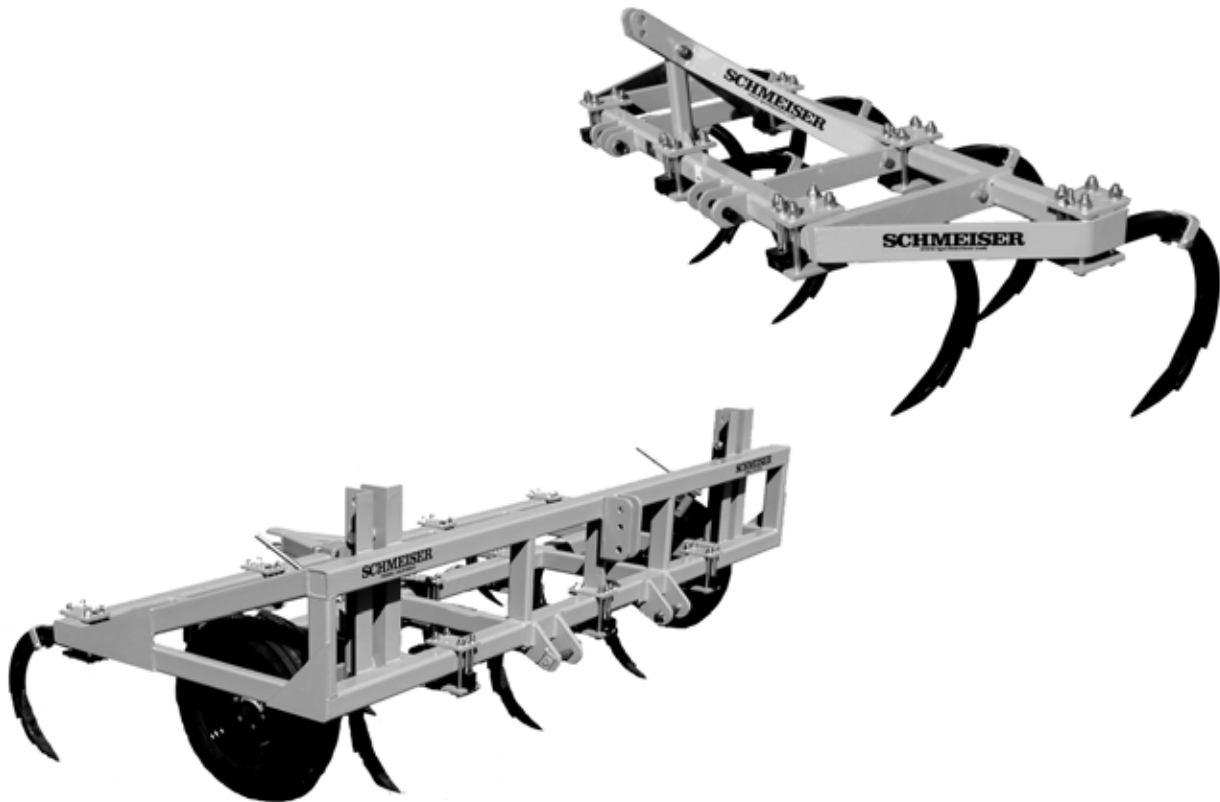

**T.G. SCHMEISER CO., INC.**  
P.O. BOX 1047 FRESNO, CA. 93714  
(559) 268-8128 FAX (559) 268-3279  
[www.tgschmeiser.com](http://www.tgschmeiser.com)

**VERSION 1.2**  
**9-2011**

## INTRODUCTION

Your Schmeiser 3-Pt. Culti-Plow is designed to give you many years of dependable service. This manual has been prepared to instruct you in the safe and efficient operation of this machine. Read and study it thoroughly. Follow all instructions carefully.

Should your 3-Pt. Culti-Plow require replacement parts, go to your Schmeiser dealer. Always order genuine Schmeiser replacement parts.

If you need information not contained in this manual, contact your Schmeiser dealer.

Space has been provided below for you to record the model number and serial number of your 3-Pt. Culti-Plow. Be sure to bring this information with you to your dealer when ordering parts for your 3-Pt. Culti-Plow.

Thank you for buying a Schmeiser 3-Pt. Culti-Plow.

SERIAL NUMBER \_\_\_\_\_

MODEL NUMBER \_\_\_\_\_

DATE PURCHASED \_\_\_\_\_

DEALER NAME \_\_\_\_\_

# TABLE OF CONTENTS

Introduction .....	2
Table of Contents .....	3
3-Pt. Culti-Plow Models.....	4
Safety Sheet.....	5
2-Bar Culti-Plow Assembly.....	6
2-Bar Culti-Plow Shank Assembly.....	7
2-Bar Culti-Plow Shank Quantity Table.....	8
3-Bar Culti-Plow Assembly.....	9
3-Bar Culti-Plow Shank Assembly .....	10
3-Bar Culti-Plow Shank Quantity Table.....	11
3-Bar Culti-Plow Gauge Leg Assembly (Optional).....	12
Limited Warranty.....	13
Maintenance and Repair Record.....	14
Notes.....	15

**SCHMEISER<sup>®</sup>**

# **3-PT. CULTI-PLOW MODELS**

## **2-Bar Models**

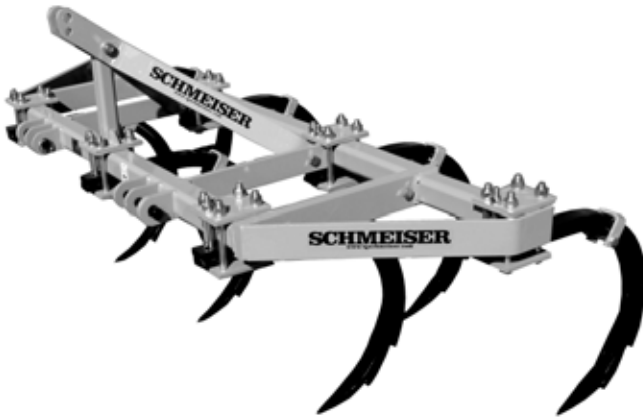

**CP-1 SINGLE SHANK CULTI-PLOW**

**CP-3 DOUBLE SHANK CULTI-PLOW**

## **3-Bar Model**



**HCP HEAVY DUTY CULTI-PLOW**

## **SAFETY**

The safe operation of any machinery is an important concern to farmers and manufactures. There are obvious and hidden potential hazards involved in the operation of this implement. Carefully read and follow all safety precautions before operation. Serious injury or death may occur unless care is taken to insure the safety of both the operator and any other persons in the area.

1. Never permit anyone to ride on or walk beside the implement when moving.
2. Never permit anyone to ride on tractor when implement is being moved.
3. When performing operating functions, never allow anyone to be near the implement or the tractor.
4. Do not enter tractor when tractor is moving. Avoid serious injury or death from contact with rotating tires. Enter and exit the tractor only when it is completely stopped.
5. Be sure of water, gas, sewer, or electric line locations before operating implement.
6. When in transport, use accessory lights and devices for adequate warning to operators of other vehicles. Comply with all Federal, State and local laws when traveling on public roads.
7. Use “Slow Moving Vehicle” emblem for warning vehicles approaching from the rear.
8. When transporting, remember that the implement may be wider than your tractor and extreme care must be taken to allow for safe clearance.
9. Never allow inexperienced or untrained personnel to operate the implement or tractor without supervision.
10. When using compressed air to clean implement, wear safety glasses.
11. Check all fasteners for tightness or damage before and after operation. Repair immediately if required.
12. Store implement in a stable position. Insure that safety stands are extended and locked in place before detaching from tractor.

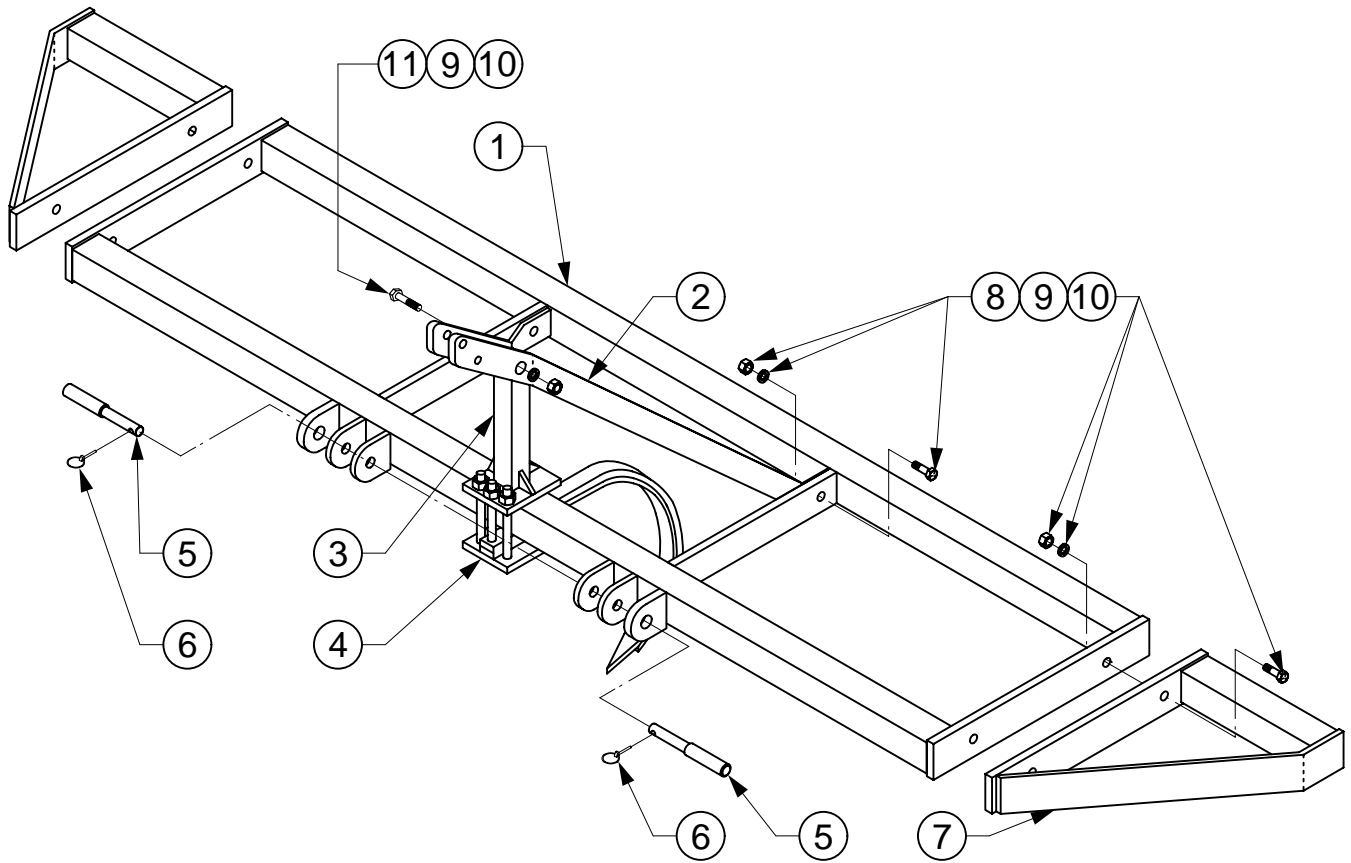

<u>Ref No.</u>	<u>Part No.</u>	<u>Description</u>	<u>Qty./Shank Assy</u>
1.	SCP-(00)B000	3-pt. Culti Plow Main Frame (specify size)	1
2.	SCP-00A200L	A-Frame Brace LH	1
	SCP-00A200R	A-Frame Brace RH	1
	SCP-00A400	A-Frame Brace Quick-Hitchable	2
3.	SCP-00A100	Culti Plow A-Frame Mast	1
	SCP-00A300	Culti Plow A-Frame Mast Quick-Hitchable	1
4.	-----	Culti Plow Shank Assembly (see p.7 for details)	varies*
5.	GPN-18CA12	Cat. 1 & 2 Pull Pin	2
6.	GPN-040LYN	1/4" Lynch Pin	2
7.	SCP-01EX00	1 Ft. Extension Frame (Optional)	2
8.	CSNC512040	3/4" X 2-1/2" Gr. 5 NC Cap Screw	2 or 6**
9.	LWASHER-12	3/4" Lock Washer	3 or 7**
10.	HXNUT-12NC	3/4" NC Hex Nut	3 or 7**
11.	CSNC512072	3/4" X 4-1/2" Gr. 5 NC Cap Screw	1
	CSNC512104	3/4" X 6-1/2" Gr. 5 NC Cap Screw (for Quick-Hitchable)	1

\* See table on page 8 for all sizes and shank quantities

\*\* Including fasteners for mounting extension frame



# 2-BAR CULTI-PLOW SHANK ASSEMBLY

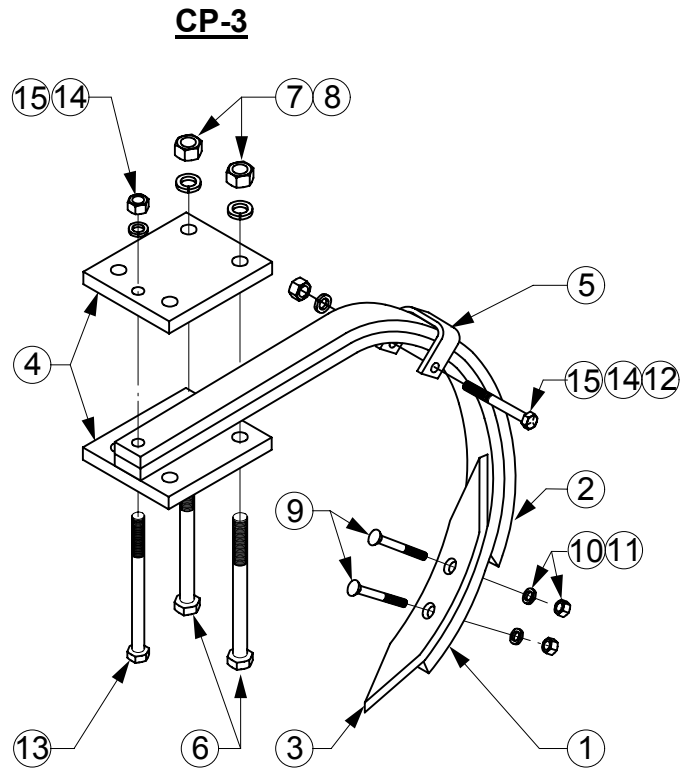
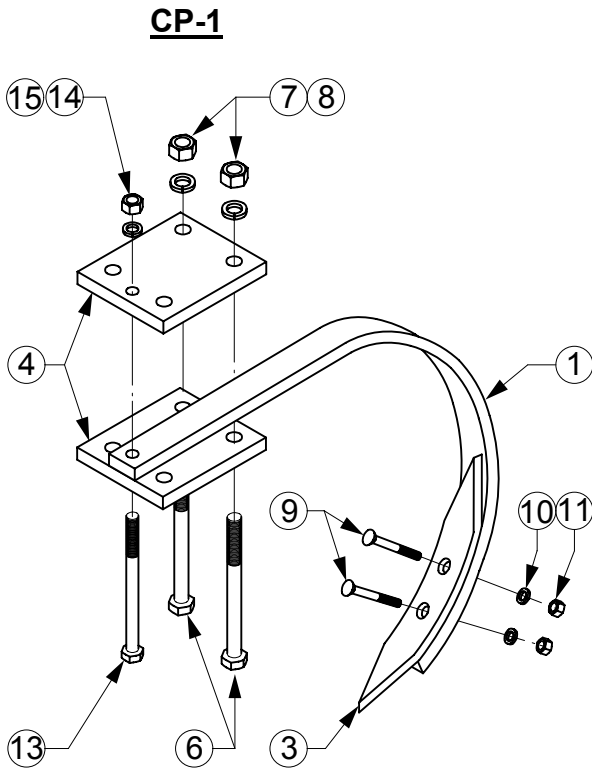

Ref No.	Part No.	Description	Qty./Shank Assy	
			CP-1	CP-3
1.	SCP0702	Shank, Chisel F-9	1	1
2.	SCP0703	Shank, Chisel B-8	-	1
3.	SCP0721	Chisel Point, Regular	1	1
4.	SCP0603	Culti-Pow Frame Clamp Plate	2	2
5.	SCP0661-01	3-1/2" Tie Clamp Plate	-	1
6.	CSNC512120	3/4" X 7-1/2" Gr.5 NC Cap Screw	4	4
7.	LWASHER-12	3/4" Lock Washer	4	4
8.	HXNUT-12NC	3/4" NC Hex Nut	4	4
9.	PBNC-08040	1/2" X 2-1/2" NC Plow Bolt	2	2
10.	LWASHER-08	1/2" Lock Washer	2	2
11.	HXNUT-08NC	1/2" NC Hex Nut	2	2
12.	CSNC510056	5/8" X 3-1/2" Gr.5 NC Cap Screw	-	1
13.	CSNC510120	5/8" X 7-1/2" Gr.5 NC Cap Screw	1	1
14.	LWASHER-10	5/8" Lock Washer	1	2
15.	HXNUT-10NC	5/8" NC Hex Nut	1	2
	SCP0645	Culti-Pow Shank Clamp Assembly (includes items 4, 6-8, 13-15)		
	SCP0661	3-1/2" Tie Clamp Assembly (includes items 5, 12, 14, 15)		

**TABLE FOR CP-1 CULTI PLOW (SINGLE SHANK)**

Ref.#	Part Number	Description	Qty.				
			4'	5'	6'	7'	8'
1.	SCP0702	Shank, Chisel F-9	5	5	5	7	7
2.	SCP0721	Chisel Point, Regular	5	5	5	7	7
3.	SCP0603	Culti Plow Frame Clamp Plate	9	9	9	13	13
4.	PBNC-08040	1/2" X 2-1/2" NC Plow Bolt	10	10	10	14	14
5.	LWASHER-08	1/2" Lock Washer	10	10	10	14	14
6.	HXNUT-08NC	1/2" NC Hex Nut	10	10	10	14	14

**TABLE FOR CP-3 CULTI PLOW (DOUBLE SHANK)**

Ref.#	Part Number	Description	Qty.				
			4'	5'	6'	7'	8'
1.	SCP0702	Shank, Chisel F-9	5	5	5	7	7
2.	SCP0702	Shank, Chisel B-8	5	5	5	7	7
3.	SCP0721	Chisel Point, Regular	5	5	5	7	7
4.	SCP0603	Culti Plow Frame Clamp Plate	9	9	9	13	13
5.	SCP0661-01	3-1/2" Tie Clamp Plate	5	5	5	7	7
6.	PBNC-08040	1/2" X 2-1/2" NC Plow Bolt	10	10	10	14	14
7.	LWASHER-08	1/2" Lock Washer	10	10	10	14	14
8.	HXNUT-08NC	1/2" NC Hex Nut	10	10	10	14	14



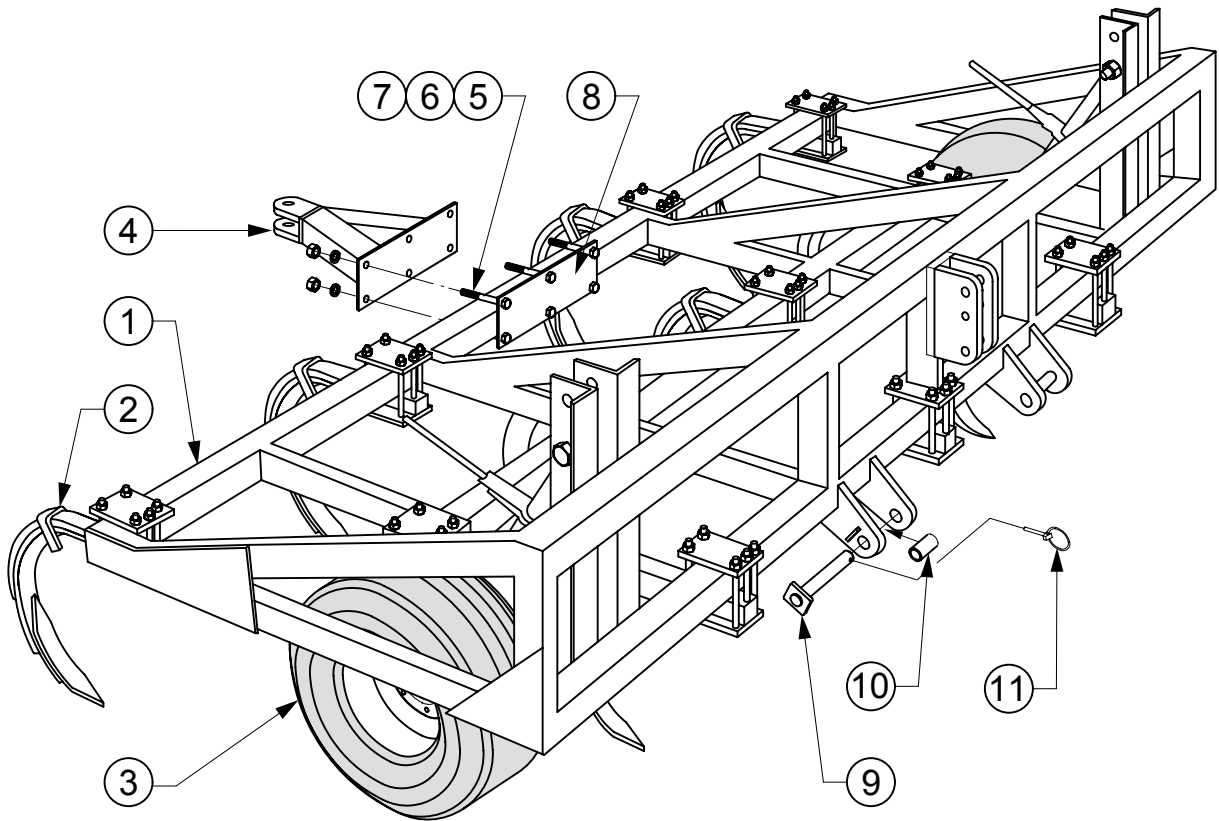

<u>Ref No.</u>	<u>Part No.</u>	<u>Description</u>	<u>Qty./Shank Assy</u>
1.	HCP-(00)P000	3-pt. HD Culti Plow Main Frame (specify size)	1
2.	-----	Shank Assembly (see p.10 for details)	varies*
3.	HCPGW	HD Culti Plow Gauge Wheel Assembly (Optional)	1
4.	HCP-00P200	HD Culti Plow Trail Hitch Weldment (Optional)	1
5.	CSNC512096	3/4" X 6" Gr.5 NC Cap Screw	6
6.	HXNUT-12NC	3/4" NC Hex Nut	6
7.	LWASHER-12	3/4" Lock Washer	6
8.	HCP-00P206	Trail Hitch Clamp Plate	1
9.	HCP-00P500	HD Culti Plow Clevis Pull Pin Weldment	2
10.	GBH-C23L01	Cat. 2 & 3 Lift Arm Bushing	2
11.	GPN-040LYN	1/4" Lynch Pin	2

\* See table on page 11 for all sizes and shank quantities

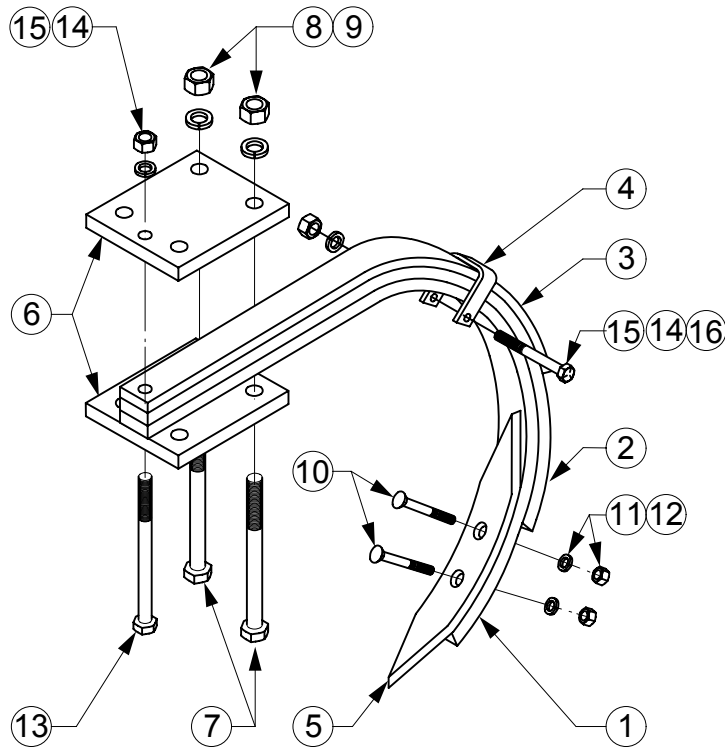

<u>Ref No.</u>	<u>Part No.</u>	<u>Description</u>	<u>Qty./Shank Assy</u>
1.	SCP0702	Shank, Chisel F-9	1
2.	SCP0703	Shank, Chisel B-8	1
3.	SCP0704	Shank, Chisel T-8	1
4.	SCP0663-01	4-1/2" Tie Clamp	1
5.	SCP0721	Chisel Point, Regular	1
6.	SCP0604	HD Culti-Plow Frame Clamp Plate	2
7.	CSNC512144	3/4" X 9" Gr.5 NC Cap Screw	4
8.	LWASHER-12	3/4" Lock Washer	4
9.	HXNUT-12NC	3/4" NC Hex Nut	4
10.	PBNC-08040	1/2" X 2-1/2" NC Plow Bolt	2
11.	LWASHER-08	1/2" Lock Washer	2
12.	HXNUT-08NC	1/2" NC Hex Nut	2
13.	CSNC510144	5/8" X 9" Gr.5 NC Cap Screw	1
14.	LWASHER-10	5/8" Lock Washer	2
15.	HXNUT-10NC	5/8" NC Hex Nut	2
16.	CSNC510056	5/8" X 3-1/2" Gr.5 NC Cap Screw	1
	SCP0646	HD Culti-Plow Shank Clamp Assembly (includes items 6-9, 13-15)	
	SCP0663	4-1/2" Tie Clamp Assembly (includes items 4, 14-16)	

**TABLE FOR HD CULTI PLOW (TRIPLE SHANK)**

Ref.#	Part Number	Description	Qty.					
			10'	12'	14'	16'	18'	20'
1.	SCP0702	Shank, Chisel F-9	9	11	13	15	17	19
2.	SCP0702	Shank, Chisel B-8	9	11	13	15	17	19
3.	SCP0704	Shank, Chisel T-8	9	11	13	15	17	19
4.	SCP0721	Chisel Point, Regular	9	11	13	15	17	19
5.	SCP0604	Culti Plow Frame Clamp Plate	17	21	25	29	33	37
6.	SCP0663-01	4-1/2" Tie Clamp Plate	9	11	13	15	17	19
7.	PBNC-08040	1/2" X 2-1/2" NC Plow Bolt	18	22	26	30	34	38
8.	LWASHER-08	1/2" Lock Washer	18	22	26	30	34	38
8.	HXNUT-08NC	1/2" NC Hex Nut	18	22	26	30	34	38

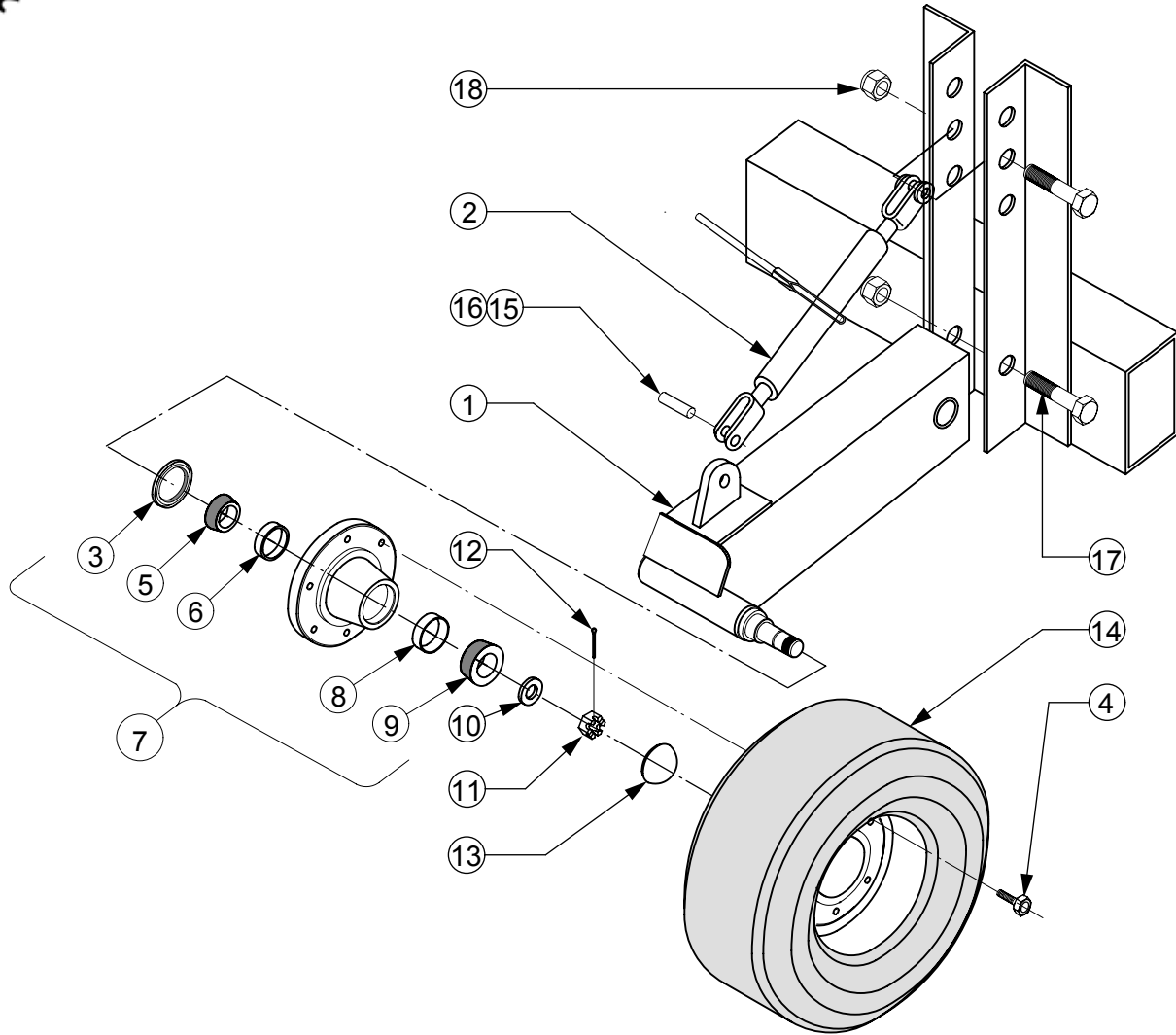

<u>Ref No.</u>	<u>Part No.</u>	<u>Description</u>	<u>Qty.</u>
1.	HCP-00P100L HCP-00P100R	Wheel Leg Weldment LH Wheel Leg Weldment RH	1 1
2.	HCP-00P300	HD Culti Plow Ratchet Weldment	2
3.	GHB-6X6GSL	Grease Seal	2
4.	WHB-08X016	1/2" x 1" UNF Wheel Bolts for 6 on 6 Std. Hub	12
5.	GHB-6X6ICN	Inner Bearing Cone for 6 on 6 Std. Hub	2
6.	GHB-6X6IRC	Inner Bearing Cup for 6 on 6 Std. Hub	2
7.	GHB-6X6STD	Standard 6 on 6 Hub Assembly Complete (includes items 3, 4, 5, 6, 8, 9, 13)	2
8.	GHB-6X6ORC	Outer Bearing Cup for 6 on 6 Std. Hub	2
9.	GHB-6X6OCN	Outer Bearing Cone for 6 on 6 Std. Hub	2
10.	GSP-14SPWA	Spindle Washer	2
11.	GSP-14CANT	Spindle Castle Nut	2
12.	GPN-03X32C	3/16" x 2" Cotter Pin	2
13.	GHB-6X6CAP	Hub Cap	2
14.	GWT-951508	9.5 x 15 8 Ply Tire with Wheel	2
15.	GPN-1656HC	1" X 3-1/2" Cylinder Pin	2
16.	GPN-03CLIP	5/32" Hair Pin Clip	4
17.	CSNC520088	1-1/4" X 5-1/2" NC Gr.5 Cap Screw	4
18.	NYNUT-20NC	1-1/4" Nylon Lock Nut	4

# T.G. SCHMEISER CO., INC.®

## Limited Warranty Statement

T. G. Schmeiser Co., Inc. warrants each new Schmeiser® product to be free from defects in material and workmanship. This warranty is applicable only for the normal service life expectancy of the product or components, not to exceed twelve (12) consecutive months from the date of delivery of the new Schmeiser product to the original purchaser.

Genuine T. G. Schmeiser Co., Inc. replacement parts and components will be warranted for 90 days from date of purchase, or the remainder of the original equipment warranty period, whichever is longer.

Under no circumstances will it cover any merchandise or components thereof, which, in the opinion of the company, has been subjected to misuse, unauthorized modifications, alteration, an accident or if repairs have been made with parts other than those obtainable through T. G. Schmeiser Co., Inc.

The Company in no way warrants engines, batteries, cylinders, tires or other trade accessories since these items are warranted separately by their respective manufacturer. Expendable components such as points, shanks, blades, rings, bearings, teeth, and the like are excluded from this warranty.

Our obligation under this warranty shall be limited to repairing or replacing, free of charge to the original purchaser, any part that, in our judgment, shall show evidence of such defect, provided further that such part shall be returned within thirty (30) days from date of failure to T. G. Schmeiser Co., Inc., routed through the dealer and distributor from whom the purchase was made, transportation charges prepaid.

This warranty shall not be interpreted to render T. G. Schmeiser Co., Inc. liable for injury or damages of any kind or nature to person or property. This warranty does not extend to the loss of crops, loss because of delay in harvesting, or any expense or loss incurred for labor, substitute machinery, rental or for any other reason.

Except as set forth above, **T. G. Schmeiser Co., Inc. shall have no obligation or liability of any kind on account of any of its equipment and shall not be liable for special or consequential damages. T. G. Schmeiser Co., Inc. makes no other warranty, expressed or implied, and, specifically, T. G. Schmeiser Co., Inc. disclaims any implied warranty or merchantability or fitness for a particular purpose. Some states or provinces do not permit limitations or exclusions of implied warranties or incidental or consequential damages, so the limitations or exclusion in this warranty may not apply.**

This warranty is subject to any existing conditions of supply, which may directly affect our ability to obtain materials or manufacture replacement parts.

T. G. Schmeiser Co., Inc. reserves the right to make improvements in design or changes in specifications at any time, without incurring any obligation to owners of units previously sold.

No one is authorized to alter, modify or enlarge this warranty nor the exclusion, limitations and reservations.

**WARRANTY VOID IF NOT REGISTERED  
WITHIN 30 DAYS OF PURCHASE DATE**



# Notes

A large rectangular box with a black border, containing 15 horizontal gray bars for writing notes. The bars are arranged in a repeating pattern of gray and white, providing a structured space for taking notes.

# Notes

A large rectangular box with a black border, containing 15 horizontal gray bars for writing notes. The bars are arranged in a repeating pattern of a gray bar followed by a white bar, starting from the top and ending at the bottom. The gray bars are approximately 15 pixels high and span the width of the box. The white bars are approximately 15 pixels high and also span the width of the box. The entire box is empty of text.